

名称: 薄款强力夹三爪D100

Model: FY56N-D100-BTS-B

夹爪基本参数

- 1.外形尺寸: 直径 $\Phi 180$ * $\Phi 138$ *高度111.5
- 2.夹持有效行程: 41mm(双作用)
- 3.驱动缸径: $\Phi 100$ mm (7854mm^2),
驱动杆直径: $\Phi 30$ mm (2356.2mm^2).
- 4.夹持力(输入气压为0.4MPa~1.2MPa时):
打开: 1468N (149.8kgf)至4404N (449.4kgf)
闭合: 1028N (105kgf)至3084N (315kgf)
- 5.气管类型: 外置(客户如需内置可以提前联系我司)
- 6.开闭时间: 0.15~0.12Sec
- 7.使用气压: 0.4~1.2Mpa
- 8.使用温度: -5°C ~ 60°C
- 9.重量: 7.45kg.
- 10.专利结构

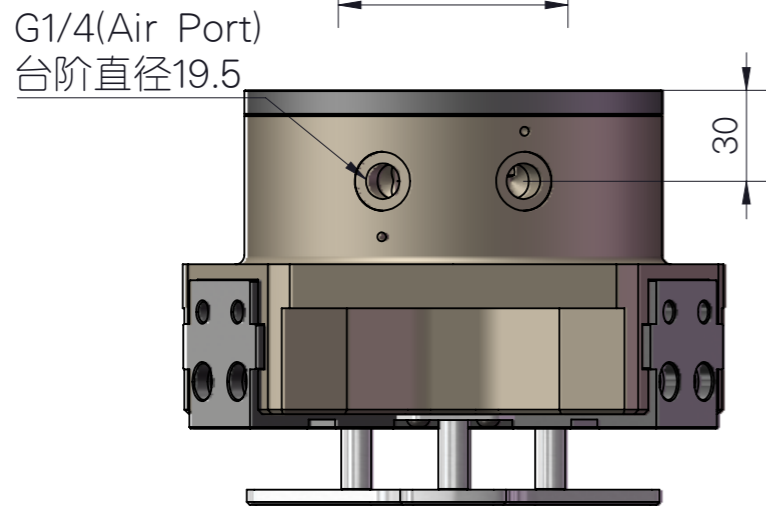
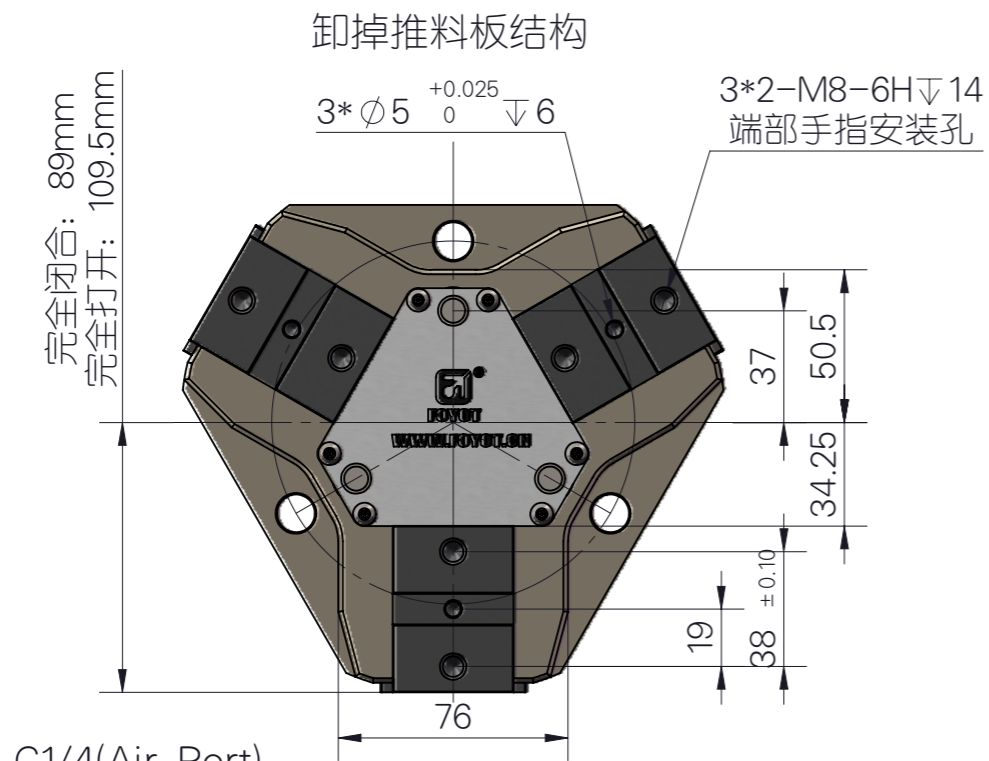
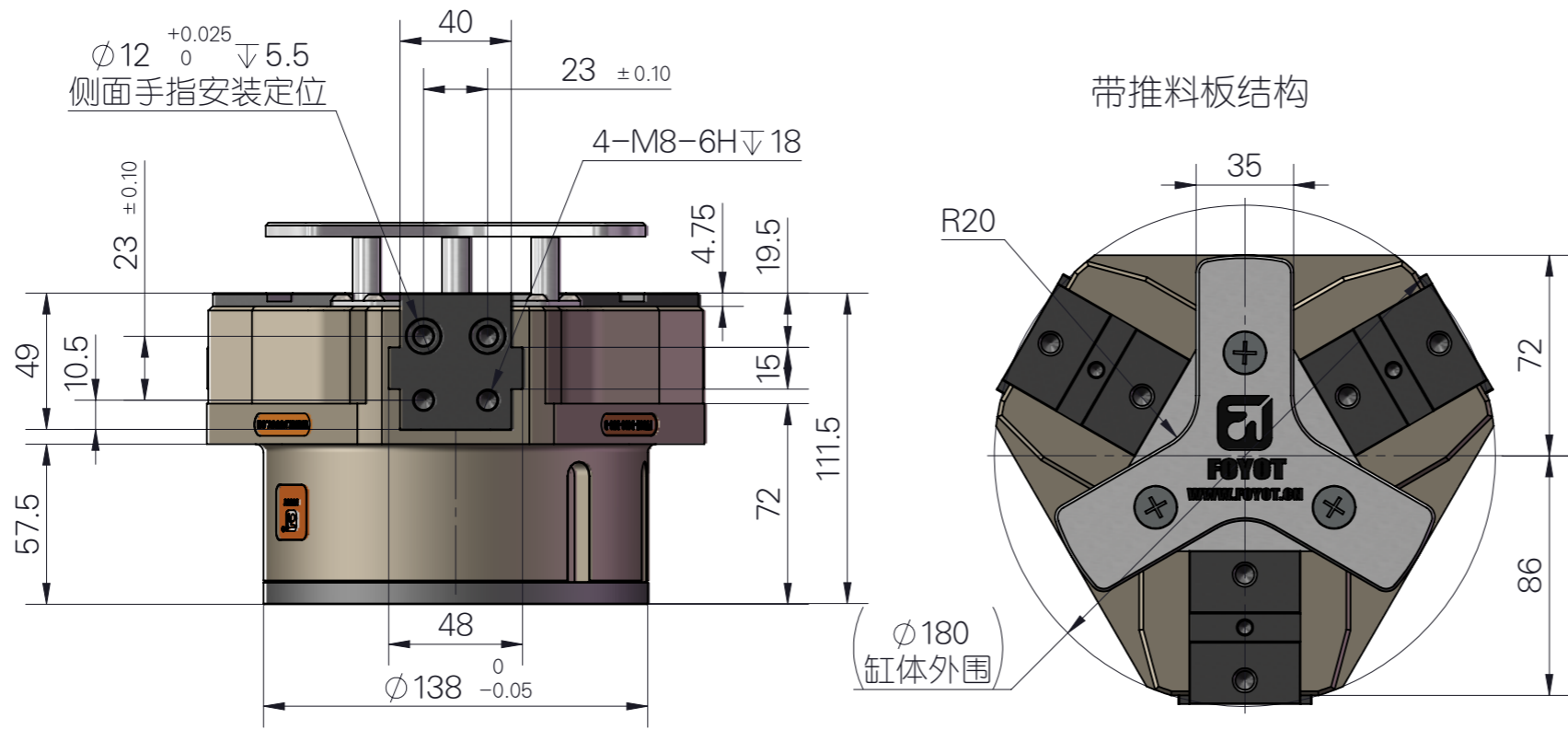

Warning:

1. When operating the gripper, please keep away from it Gripper and robot's moving parts, otherwise it will Risk of personal injury;
2. Because different objects have different friction coefficients, When clamping the workpiece for the first time, please try clamping in an open field. Ensure that the clamping is firm before the machine can work, otherwise it will There is a risk that falling workpieces may damage machines or personnel.

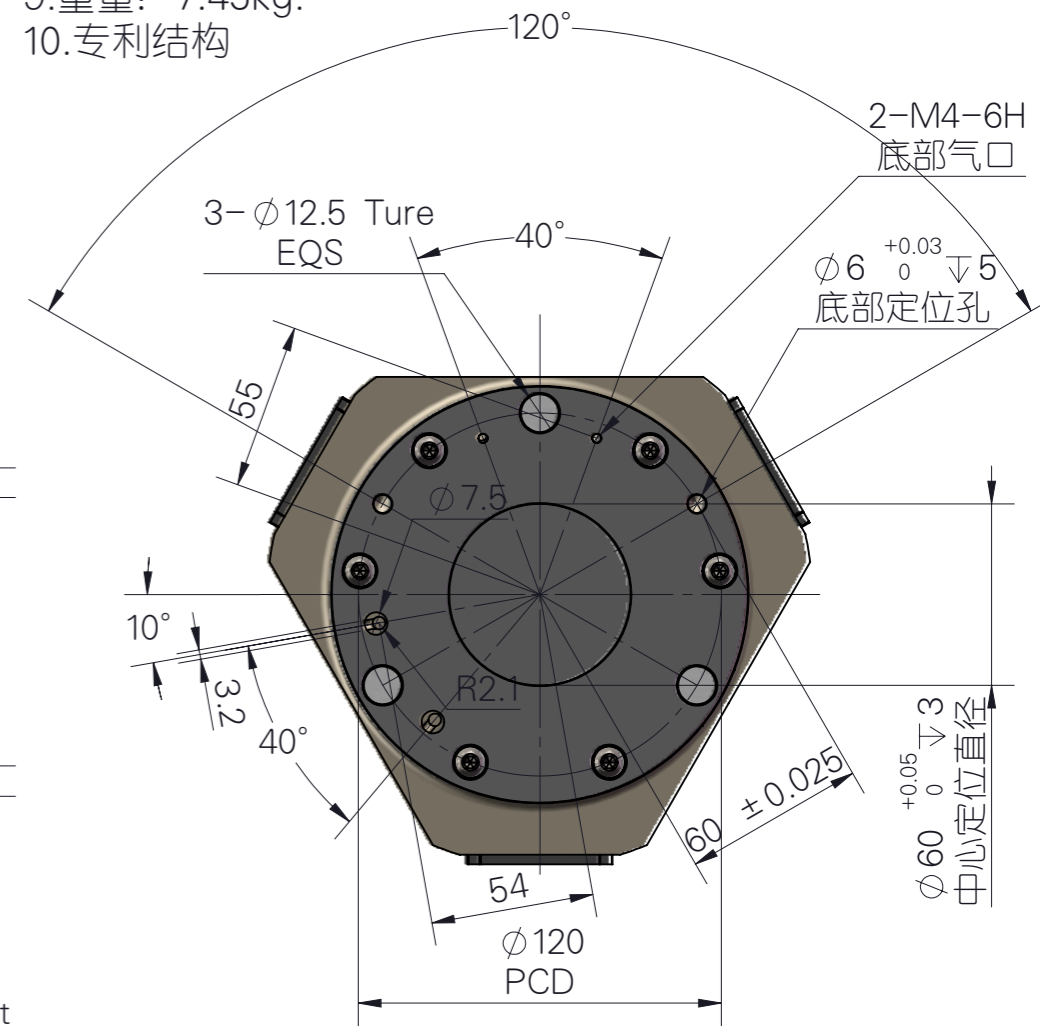

警告:

- 1.当操作夹爪工作时, 请人员务必远离夹爪和机器人的活动部位, 否则将会造成人身伤害的险;
- 2.由于不同物件有其不同的摩擦系数, 当初次夹持工件时, 请在空旷场地进行试夹, 确保夹稳固后方可装机工作, 否则将会有跌落工件砸伤机器或人员的风险